

UDC 624.04

STRESS STATE OF COMPRESSED REINFORCED CONCRETE ELEMENTS CONSIDERING CREEP AND INFLUENCE OF AN AGGRESSIVE ENVIRONMENT

M. Bekirova¹

¹*Odessa State Academy of Civil Engineering and Architecture*

Abstract: Problems associated with the joint long-term action of load and aggressive environment, both in limiting and over-limiting states, are studied bad. Such a combination leads to degradation of materials and changes in the stress-strain state of reinforced concrete structures over time. In case of joint action, they can have mutually increasing damaging effect. Among the many environmental influences encountered, the most aggressive in relation to concrete on cement binder is the impact of sulfates, and in relation to steel reinforcement – the impact of chlorides.

It is shown that the stress-strain state of reinforced concrete compressed elements with regard to creep and influence of aggressive environment is formed in time.

The deformation in concrete and reinforced concrete compressed elements depends on the stress level. If the stresses are less than the long-term strength, the deformations in time are attenuated, when the stresses in concrete are greater than the long-term strength, the deformations increase. Reinforcement restrains deformations in concrete, while corrosive medium increases creep deformations.

When solving these problems we encounter internally statically indeterminate systems. The degree of static indeterminacy is greater than in the case of calculation of reinforced concrete structures without taking into account the influence of the external environment. When the process of soaking is considered, it is possible to consider the influence of the external environment as not aggressive.

A solution to the problem using the theory of elastic heredity has been obtained, but it can be shown that a solution using other theories - the theory of aging or the hereditary theory of aging - is also possible.

The above solution is true for reinforced concrete elements exposed to external influences at a sufficiently mature age, which can be considered one year or more from the date of manufacture of the structure.

Keywords: concrete, reinforcement, creep, long-term strength, aggressive environment, deformation, theory of elastic heredity.

НАПРУЖЕНО-ДЕФОРМОВАНИЙ СТАН СТИСНЕНИХ ЗАЛІЗОБЕТОННИХ ЕЛЕМЕНТІВ З УРАХУВАННЯМ ПОВЗУЧОСТІ І ВПЛИВУ АГРЕСИВНОГО СЕРЕДОВИЩА

Бекірова М. М.¹

¹*Одеська державна академія будівництва та архітектури*

Анотація: Задачи, связанные с совместным длительным действием нагрузки и агрессивной среды, как в предельных, так и запредельных состояниях, изучены значительно хуже. Такое сочетание приводит к деградации материалов и изменению напряженно-деформированного состояния железобетонных конструкций с течением времени. В случае совместного действия они могут обладать взаимно усиливающим повреждающим эффектом. Среди множества встречающихся воздействий среды наиболее агрессивны по отношению к бетону на цементном вяжущем воздействия сульфатов, а по отношению к стальной арматуре – воздействия хлоридов.

Показано, что напряженно-деформированное состояние железобетонных сжатых элементов с учетом ползучести и влияния агрессивной среды формируется во времени.

Деформация в бетонных и железобетонных сжатых элементах зависит от уровня напряжений. Если напряжения меньше длительной прочности, деформации во времени затухают, когда напряжения в бетоне больше длительной прочности, деформации увеличиваются. Арматура сдерживает деформации в бетоне, в то время как агрессивная среда увеличивает деформации ползучести.

При решении этих задач сталкиваемся с внутренне статически неопределенными системами. Степень статической неопределимости больше, чем в случае расчёта железобетонных конструкций без учёта влияния внешней среды. Когда рассматривается процесс замачивания, можно считать влияние внешней среды не агрессивным.

Получено решение задачи с использованием теории упругой наследственности, однако можно показать, что возможно решение и с применением других теорий – теории старения или наследственной теории старения.

Приведенное решение справедливо для железобетонных элементов, подверженных внешним воздействиям в достаточно зрелом возрасте, которым можно считать один год и более с момента изготовления конструкции.

Ключові слова: бетон, арматура, ползучість, довготривала міцність, агресивна середовище, деформація, теорія пружної успадкованості.

1 INTRODUCTION

Building materials that are used in load-bearing structures have the property of creep, which, as we know, means the ability to deform over time under constant stresses. The problems of calculating structures in such a formulation have already been solved. It makes sense to consider cases of stresses change in time, namely periods of their increase.

Deformations and displacements increase with prolonged exposure. Over time, a limit state can occur. Creep in this case shows negative qualities. But not always, for example, during deformations caused by shrinkage, temperature changes, irregular settlement of supports, stresses are attenuated, relaxation occurs. In reinforced concrete structures there is a redistribution of forces. The forces in concrete, as the weaker material, are redistributed to the reinforcement.

Some building materials such as concrete, wood, plastics have aging properties. They change their physical and mechanical properties over time. In concrete, aging is a consequence of hardening of cement stone and manifests itself as an increase in strength and a decrease in deformability. A number of theories have been developed for the calculation of building structures taking into account creep, the main ones being the theory of elastic heredity, the theory of aging and the hereditary theory of aging [1].

2 LITERATURE DATA ANALYSIS AND PROBLEM FORMULATION

A great number of works are devoted to the study of concrete properties and its state in reinforced concrete elements under various operational influences. At the same time, problems associated with the joint long-term action of loading and aggressive medium, both in limiting and over-limiting states, are studied much worse [2]. This combination leads to degradation of materials and changes in the stress-strain state of reinforced concrete structures over time. In the case of joint action, they can have a mutually reinforcing damaging effect [3-4].

Let's note the works [5-14], where it is shown that among the occurring environmental influences the most aggressive in relation to the concrete on the cement binder is the impact of sulfates, and in relation to the steel reinforcement - the impact of chlorides.

The interest in the problem does not decrease, as evidenced by a number of modern publications. Thus, the creep of concrete at the macroscopic level and consideration of its influence on the structural behavior of the material in the mathematical apparatus of applied mechanics and numerical analysis are considered in [15]. The creep and durability of reinforced concrete structural elements is studied in [16, 17]. Similar issues, but for fiber concrete, are considered in [18]. A finite-element model based on a nonlinear relationship between stresses and strains in reinforced concrete, taking into account the peculiarities of its operation after cracking is proposed in [19]. The functional dependence describing this relationship changes, for example, as reinforcement corrosion develops. The problem of considering the time factor in calculations of reinforced concrete structures is devoted to [20]; the results of experimental studies of concretes at different levels of compressive stresses loaded at young and middle age are given.

The above brief review shows that the consideration of creep and the influence of aggressive environment in the work of reinforced concrete structures continues to be an urgent problem.

3 RESEARCH GOAL AND OBJECTIVES

The purpose of this work is to investigate the stress-strain state of compressed reinforced concrete elements, taking into account creep and the influence of aggressive environment.

4 RESEARCH RESULTS

Consider a compressed reinforced concrete rod with zones of symmetrical influence of corrosive environment in depth h_v (Fig. 1), the core of the rod creeps at the same time h_c and influence area h_v . If the reinforced concrete bar is operating at normal temperature, then the rebar will not creep.

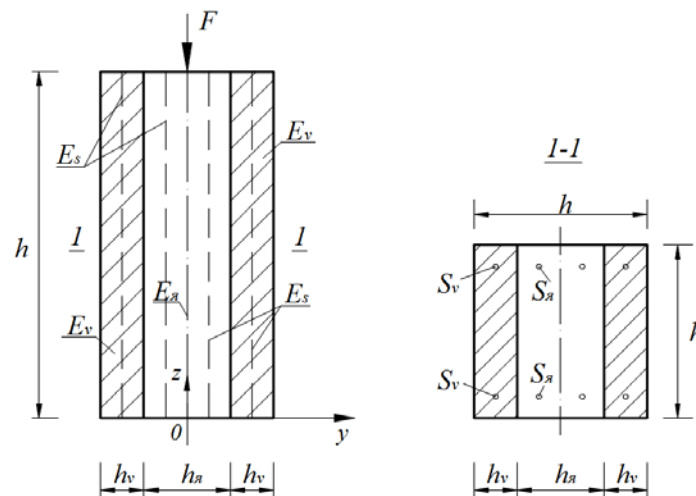

Fig. 1. Compressed reinforced concrete element with zones of symmetrical influence of aggressive environment h_v

Let's make an equation of equilibrium on the axis z

$$F = N_c + N_v + N_s \tag{1}$$

or through stresses $\sigma_{sc} = \sigma_{sv} = \sigma_s$.

$$F = (A_0 - A_v)\sigma_c + A_v \cdot \sigma_v + A_s \cdot \sigma_s.$$

Dividing (1) by A_0 :

$$\sigma_0 = (1 - \mu\nu)\sigma_c + \mu_v \cdot \sigma_v + \mu_s \cdot \sigma_s \cdot \sigma_0 \frac{F}{A_0}. \tag{2}$$

An equation with three unknowns is obtained, i.e. the problem is statically indeterminate. We must use the condition of joint deformation

$$\varepsilon_c = \varepsilon_v - \varepsilon_s. \tag{3}$$

The problem is solved in a physically linear formulation, taking into account creep [1].



$$\varepsilon_c(t) = \frac{\sigma_a(t)}{E_c(t)} \int_0^t \sigma_c(\tau) \frac{\partial \delta_c(t, \tau)}{\partial \tau} d\tau;$$

$$\varepsilon_v(t) = \frac{\sigma_v(t)}{E_v(t)} \int_{\tau_1}^t \sigma(\tau) \frac{\partial \delta_v(t, \tau)}{\partial \tau} d\tau, \quad \varepsilon_s = \frac{\sigma_s}{E_s},$$

here $\delta(t, \tau)$ – total relative strain;

$$\delta_c(t, \tau) = \frac{1}{E_\gamma} + C_c(t, \tau); \quad \delta_v(t, \tau) = \frac{1}{E_\nu} + C_v(t, \tau), \quad (4)$$

$C(t, \tau)$ – creep factor.

In solving this problem, we will apply the theory of elastic heredity. Then $C(t, \tau)$ for the core and the impact zone has the form:

$$C(t, \tau) = C_0 [1 - e^{-\gamma(t-\tau)}], \quad (5)$$

where C_0 – creep limit.

According to (3) $\gamma_c = \gamma_v = \gamma$.

Let's write the stresses through the resolvent

$$\sigma_{bc}(\tau) = E_c \left[\varepsilon_c(\tau) + \int_{\tau_1}^t \varepsilon_c(\tau) R_c(t, \tau) d\tau \right]. \quad (6)$$

By (3) $\varepsilon_c(t) = \varepsilon_s(\tau)$ instead of ε_c we substitute $\varepsilon_s = (\sigma_s/E_s) \cdot R_c$, take according to the creep measure $C_c(t, \tau) = C_{0c} [1 - e^{-\gamma(t-\tau)}]$, then

$$R_c(t-\tau) = -\gamma \varphi_{0c} e^{-\gamma(1+\varphi_{0c})(t-\tau)}, \quad (7)$$

$\varphi_{0\gamma} = E_\gamma C_{0\gamma}$ – creep characteristic. Let's write down $r_\gamma = (1 + \varphi_{0\gamma})$ and substitute (7) into (6).

$$\sigma_c(\tau) = E_c \left[\frac{\sigma_c(\tau)}{E_s} - \gamma \varphi_{0c} \frac{1}{E_s} \int_{\tau_1}^t \sigma_s(\tau) \cdot e^{-r_c(t-\tau)} d\tau \right],$$

$$\sigma_c(\tau) = \alpha_{cs} \left[\sigma_s(\tau) - \gamma \varphi_{0c} \frac{1}{E_s} \int_{\tau_1}^t \sigma_s(\tau) \cdot e^{-r_c(t-\tau)} d\tau \right]. \quad (8)$$

Similarly write down $\sigma_v(\tau)$

$$\sigma_v(\tau) = \alpha_{vs} \left[\sigma_s(\tau) - \gamma \varphi_{0v} \frac{1}{E_s} \int_{\tau_1}^t \sigma_s(\tau) \cdot e^{-r_v(t-\tau)} d\tau \right]. \quad (9)$$

Substituting (8) and (9) into (2), we get one equation with one unknown $\sigma_s(\tau)$.

$$\sigma_0 = b_0 \sigma_s(\tau) - b_1 \int_{\tau_1}^t \sigma_s(\tau) e^{-r_c(t-\tau)} d\tau - b_2 \int_{\tau_1}^t \sigma_s(\tau) e^{-r_v(t-\tau)} d\tau, \quad (10)$$

where $b_0 = (1 - \mu_v) \alpha_{cs} + \mu_r \alpha_{sv} + \mu_s$, $b_1 = (1 - \mu_v) \gamma \varphi_{0c} \cdot \alpha_{cs}$, $b_2 = \mu_v \cdot \gamma \cdot \varphi_{0v} \cdot \alpha_{vs}$.

The integral equation (10) can be reduced to a differential equation if we differentiate twice by t [21].

Let us differentiate equation (10) by t .

$$\dot{\sigma}_0(t) = b_0 \dot{\sigma}_s(t) - b_1 \sigma_s(t) + r_c b_1 \int_{\tau_1}^t \sigma_s(\tau) \cdot e^{-r_c(t-\tau)} - b_2 \dot{\sigma}_s(t) + r_v b_2 \int_{\tau_1}^t \sigma_s(\tau) \cdot e^{-r_v(t-\tau)}. \quad (11)$$

Let's multiply equation (10) by r_c and summing with equation (11), the first integral is reduced. In equation (11), the left part of the derivative is $\dot{\sigma}_0(t)$. It means that force F can change its value over time – $F(t)$.

After summing up the equations, we get:

$$\dot{\sigma}_0(t) + r_c \sigma_0(t) = b_0 \dot{\sigma}_s(t) - b_3 \sigma_s(t) + b_4 \int_{\tau_1}^t \sigma_s(\tau) \cdot e^{-r_v(t-\tau)} d\tau, \quad (12)$$

where $b_3 = b_1 + b_2 - r_c b_0$; $b_4 = b_2(r_v - r_c)$.

Equation (12) is differentiated by t and summarize with equation (12), which will have to be multiplied by r_v .

The integrals are reduced and we obtain a differential equation with respect to $\sigma_s(t)$. Force F will be assumed to be independent of t , it's constant.

Omitting intermediate results, let us write the differential equation

$$b_0 \cdot \ddot{\sigma}_s(t) + b_5 \cdot \dot{\sigma}_s(t) + b_6 \cdot \sigma_s(t) = r_c r_v \sigma_0, \quad (13)$$

where $b_5 = b_0(r_v + r_c) - (b_1 + b_2)$;

$$b_6 = r_c r_v b_0 - b_1 r_v - b_2 r_c. \quad (14)$$

If $b_0 = 1$, we will get

$$\ddot{\sigma}_s(t) + b_7 \cdot \dot{\sigma}_s(t) + b_8 \cdot \sigma_s(t) = b_9 \cdot \sigma_0, \quad (15)$$

where

$$b_7 = \frac{b_5}{b_0}; \quad b_8 = \frac{b_6}{b_0}; \quad b_9 = \frac{r_c r_v}{b_0}. \quad (16)$$

Let's solve the equation (15)

$$\sigma_s(t) = C_1 e^{\lambda_1 t} + C_2 e^{\lambda_2 t} + C_3. \quad (17)$$

Stresses depend on two variables t and τ .

Equation (15) and its solution are written for old concrete when the creep is decaying. Thus C_1 and C_2 we determine from the initial conditions, C_3 at $t \rightarrow \infty$.

To determine λ let's substitute the solution of the homogeneous part $Ce^{\lambda t}$ into the homogeneous part of equation (15).

$\lambda^2 C e^{\lambda t} + b_7 \lambda C e^{\lambda t} + b_8 C e^{\lambda t} = 0$ and obtain an equation, by solving which we determine λ .

$$\lambda^2 + b_7 \lambda + b_8 = 0,$$

$$\lambda_{1,2} = -0,5b_7 \pm \sqrt{0,25b_7^2 - b_8}.$$

The general solution of the homogeneous part of (15) will be

$$\sigma_s^0 = C_1 e^{\lambda_1 t} + C_2 e^{\lambda_2 t}. \quad (18)$$

Partial solution with the right part $\bar{\sigma}_s(t \rightarrow \infty)$.

For $t \rightarrow \infty$ let's determine the long-term moduli of elasticity.



$$E_{bc}^l = \frac{E_{bc}}{(1 + \varphi_{0c})}; \quad E_{bv}^l = \frac{E_{bv}}{(1 + \varphi_{0v})}.$$

From the coincidence of deformations for $t \rightarrow \infty$

$$\frac{\sigma_c(\infty)}{E_{bc}^l} = \frac{\sigma_s}{E_s} \cdot \sigma_c(\infty) = \frac{E_{bc}^l}{E_s} \sigma_s = \sigma_s \alpha_{cs}^l.$$

Similarly $\sigma_v(\infty) = \sigma_s \alpha_{vs}^l$.

$\sigma_c(\infty)$ and $\sigma_v(\infty)$ we substitute into equation (2).

$$\sigma_0 = (1 - \mu\nu)\sigma_s \alpha_{cs}^l + \mu\nu\sigma_s \alpha_{vs}^l + \mu\nu\sigma_s.$$

From this we find σ_s^l .

$$\sigma_s(\infty) = \frac{\sigma_0}{(1 - \mu\nu)\alpha_{cs}^l + \mu\nu\lambda_{vs} + \mu_s}. \quad (19)$$

5 DISCUSSION OF RESEARCH RESULTS

Stress $\sigma_s(\infty)$ for reinforced concrete rod means, that for $t \rightarrow \infty$, it is a time, when creep deformations are attenuated. it could be 10-20 years.

For such a time, the solution of this equation gives a concrete idea of how creep and corrosive environment affect the stress state of a reinforced concrete rod. but during design, care must be taken to ensure that the stresses in the concrete do not reach the level of the long-term strength of the concrete.

Thus, general solution:

$$\sigma_s(t) = C_1 e^{\lambda_1 t} + C_2 e^{\lambda_2 t} + \sigma_s(\infty). \quad (20)$$

The arbitrary constants are defined at $t = \tau_1$, that is, it is an elastic-momentary problem.

We obtain a system of equations

$$\begin{aligned} C_1 e^{\lambda_1 \tau_1} + C_2 e^{\lambda_2 \tau_1} &= \sigma_s(\tau_1) - \sigma_s(\infty), \\ \lambda_1 C_1 e^{\lambda_1 \tau_1} + \lambda_2 C_2 e^{\lambda_2 \tau_1} &= b_9 \sigma_s(\tau_1). \end{aligned} \quad (21)$$

When solving this system, we obtain

$$C_1 = \frac{\sigma_s(\tau_1)(b_9 - \lambda_2) + \sigma_s(\infty)\lambda_2}{b_7 + \sqrt{0,25b_7^2 - b_8}} e^{-\lambda_1 t}, \quad (22)$$

$$C_2 = \frac{\sigma_s(\tau_1)(b_9 - \lambda_1) + \sigma_s(\infty)\lambda_1}{-b_7 - \sqrt{0,25b_7^2 - b_8}} e^{-\lambda_2 t}. \quad (23)$$

Let's introduce notations and substitute $C_1 = b_{10} e^{-\lambda_1 t}$ and $C_2 = b_{11} e^{-\lambda_2 t}$ into equation (20),

where

$$\begin{aligned} b_{10} &= \frac{\sigma_s(\tau_1)(b_9 - \lambda_2) + \sigma_s(\infty)\lambda_2}{b_7 + \sqrt{0,25b_7^2 - b_8}}, \\ b_{11} &= \frac{\sigma_s(\tau_1)(b_9 - \lambda_1) + \sigma_s(\infty)\lambda_1}{-b_7 - \sqrt{0,25b_7^2 - b_8}}, \end{aligned} \quad (24)$$



$$\sigma_s(t, \tau) = b_{10} \cdot e^{-\lambda_1(t-\tau_1)} + b_{11} \cdot e^{-\lambda_2(t-\tau_1)} + \sigma_s(\infty). \quad (25)$$

By stresses $\sigma_s(t, \tau)$ let's determine the deformations

$$\varepsilon_s(t, \tau) = \frac{\sigma_s(t, \tau)}{E_s}. \quad (26)$$

The condition of joint deformation is also true in the case of prolonged deformation.

$$\varepsilon_c(t, \tau_1) = \varepsilon_s(t, \tau_1) = \frac{\sigma_s(t, \tau_1)}{E_s} = \frac{\sigma_c(t, \tau)}{E_c}, \quad (27)$$

$$\sigma_c(t, \tau_1) = \sigma_s(t, \tau_1) \frac{E_c}{E_s} = \sigma_c \alpha_{cs}, \quad (28)$$

$$\varepsilon_v(t, \tau_1) = \varepsilon_s(t, \tau_1) = \frac{\sigma_s(t, \tau)}{E_s} = \frac{\sigma_v(t_1, \tau)}{E_v}, \quad (29)$$

$$\sigma_c(t, \tau) = \sigma_s(t, \tau_1) = \frac{E_v}{E_s} = \sigma_s(t, \tau_1) \alpha_{vs}. \quad (30)$$

Stresses and strains increase over time. stresses should not be greater than a certain value and should remain constant over time.

Let this be the operating time t_E and stresses $\sigma_c(t_E)$ and $\sigma_v(t_E)$ no longer grow.

$$\varepsilon_v(t_E) = \sigma_v(t_E) \delta_v(t_E, \tau_2),$$

$$\varepsilon_s(t_E) = \frac{\sigma_s(t_E)}{E_s}.$$

We apply the condition of coincidence: $\varepsilon_c(t_E) = \varepsilon_v(t_E)$, $\sigma_c(t_E) \delta_c(t_E, \tau_1) = \sigma_v(t_E) \delta_v(t_E, \tau_1)$ we get

$$\sigma_v(t_E, \tau_1) = \sigma_c(t_E) \frac{\delta_c(t_E, \tau_1)}{\delta_v(t_E, \tau_1)}, \quad (30)$$

$$\frac{\sigma_s(t_E)}{E_s} = \sigma_c(t_E) \delta_c(t_E, \tau_1), \quad \sigma_s(t_E) = \sigma_c(t_E) \frac{\delta_c(t_E, \tau_1)}{E_s}. \quad (31)$$

Let's substitute the stress values in equation (1).

$$F_{t_E} = \left[(A_0 - A_b) \delta_c(t_E - \tau_1) + A_b \frac{\delta_c(t_E, \tau_1)}{\delta_v(t_E - \tau_1)} + \mu_s \frac{\delta_c(t_E, \tau_1)}{E_s} \right] \sigma_c(t_E, \tau_1). \quad (32)$$

If compressing force F_{t_E} will be determined by this formula, then the stresses will become constant from the moment t_E .

6 CONCLUSIONS

Thus, the stress-strain state of reinforced concrete compressed elements with regard for creep and influence of corrosive medium is formed in time. A solution of the problem using the theory of elastic heredity has been obtained, but it can be shown that a solution using other theories is also possible.

The above solution is true for reinforced concrete elements exposed to external influences at a sufficiently mature age, which can be considered one year or more from the date of the structure manufacture.

References

1. Ulitskiy, I. I., Chzhan, Ya. O., Golyshev A. B. (1967). *Teoriya i raschet zhelezobetonnykh sterzhnevnykh konstruksiy s uchetom dlitelnykh protsessov*. [Theory and calculation of reinforced concrete bar structures, taking into account long-term processes]. Kiev: Budivelnik. [in Russian].
2. Bondarenko, V. M., Kolchunov, V. I. (2013). *Kontseptsiya i napravleniya razvitiya teorii konstruktivnoy bezopasnosti zdaniy i sooruzheniy pri silovykh i sredovykh vozdeystviyakh*. [The concept and directions of development of the theory of constructive safety of buildings and structures under force and environmental influences]. *Promyshlennoe i grazhdanskoe stroitelstvo*. 2. 28–31. [in Russian].
3. Selyaev, V. P., Solomatov, V. I., Oshkina, L. M. (2001). *Khimicheskoe soprotivlenie napolnennykh tsementnykh kompozitov*. [Chemical resistance of filled cement composites]. Saransk: Izd-vo Mordov. un-ta. [in Russian].
4. Pukhonto, L. M. (2004). *Dolgovechnost zhelezobetonnykh konstruksiy inzhenernykh sooruzheniy: (silosov, bunkerov, rezervuarov, vodonapornykh bashen, podpornykh sten)*. [Durability of reinforced concrete structures of engineering structures: (silos, bunkers, tanks, water towers, retaining walls)] *Monografiya Izd-vo ASV*. [in Russian].
5. Vasilev, A. I., Podvalnyy, A. M. (2002). *Prognoz korrozii armatury zhelezobetonnykh konstruksiy avtodorozhnykh mostov v usloviyakh khloridnoy agressii i karbonizatsii*. [Prediction of Corrosion of Reinforcement for Reinforced Concrete Structures of Highway Bridges in Conditions of Chloride Aggression and Carbonization]. *Beton i zhelezobeton*. № 6. 27–32. [in Russian].
6. Dronov, A. B. (2017). *Prochnost i deformativnost zhelezobetonnykh izgibaemykh elementov s korroziionnymi povrezhdeniyami: dis. ... kand. tekhn. nauk: 05.23.01* [Strength and deformability of reinforced concrete bending elements with corrosion damage]. Belgorod. [in Russian].
7. Migunov, V. N. (2016). *Dlitelnye eksperimentalnye issledovaniya modeley zhelezobetonnykh konstruksiy s treshchinami v agressivnoy khloridsoderzhashchey srede: monogr.* [Long-term experimental studies of models of reinforced concrete structures with cracks in an aggressive chloride-containing environment]. Penza: PGUAS. [in Russian].
8. Ovchinnikov, I. I., Migunov, V. N., Ovchinnikov, I. G. (2014). *Modelirovanie kinetiki deformirovaniya armirovannykh konstruksiy v spetsialnykh ekspluatatsionnykh sredakh: monogr.* [Modeling the kinetics of deformation of reinforced structures in special operating environments]. Penza: PGUAS. [in Russian].
9. Popesko, A. I. (1996). *Rabotosposobnost zhelezobetonnykh konstruksiy, podverzhennykh korrozii*. [Efficiency of reinforced concrete structures subject to corrosion]. SPb.: SPb gos. arkh.- stroit. un-t. [in Russian].
10. Rozental, N. K., Stepanova, V. F., Chekhniy, G. V. (2017). *Khlорidy v betone i ikh vliyanie na razvitie korrozii stalnoy armatury*. [Chlorides in concrete and their influence on the development of corrosion of steel reinforcement]. *Promyshlennoe i grazhdanskoe stroitelstvo*. № 1. 92–96. [in Russian].
11. Selyaev, V. P., Selyaev, P. V., Alimov, M. F., Sorokin, Ye. V. (2017). *Otsenka ostatochnogo resursa zhelezobetonnykh izgibaemykh elementov, podverzhennykh deystviyu khlорidnoy korrozii*. [Estimation of the residual life of reinforced concrete bending elements exposed to chloride corrosion] *Stroitelstvo i rekonstruksiya*. № 6 (74). 49–58. [in Russian].
12. Smolyago, G. A., Dronov, A. B., Frolov, N. V. (2017). *Modelirovanie velichiny korroziionnykh povrezhdeniy armatury zhelezobetonnykh konstruksiy v usloviyakh khlорidnoy agressivnoy sredy*. [Modeling the magnitude of corrosion damage to reinforcement of reinforced concrete structures in

- a chloride aggressive environment]. *Izvestiya Yugo- Zapadnogo gosudarstvennogo universiteta*. № 1 (70). 43–49. [in Russian].
13. Sorokin, Ye. V. (2014) *Raschet i prognozirovaniye dolgovechnosti zhelezobetonnykh konstruksiy*: dis. ... kand. tekhn. nauk: 05.23.01 [Calculation and forecasting of durability of reinforced concrete structures] Saransk. [in Russian].
14. Fedosov, S. V., Rumyantseva, V. Ye., Konovalova, V. S. (2016). Issledovanie protsessov korrozionnoy destruktzii zhelezobetonnykh izdeliy v agressivnykh sredakh s khlorid-ionami. [Investigation of the processes of corrosion destruction of reinforced concrete products in corrosive environments with chloride ions]. *Vestnik grazhdanskikh inzhenerov*. № 5 (58). 61–67. [in Russian].
15. England, G. L. (1980). Creep and temperature effects in concrete structures: reality and prediction. *Applied Mathematical Modelling*. Volume 4. Issue 4. 261–267.
16. Breslavskiy, D. V., Chuprynin, A. A., Sereda, N. V. (2015). Polzuchest zhelezobetonnykh elementov konstruksiy. [Creep of reinforced concrete structural members] *Vestnik Nats. tekhn. un-ta "KhPI" : sb. nauch. tr. Temat. vyp. : Dinamika i prochnost mashin*. [Bulletin of the National Technical University "KhPI": collection of articles. scientific. tr. Topic. no. : Dynamics and strength of machines]. Kharkov : NTU "KhPI". № 55 (1164). 22–25. [in Russian].
17. Chuprynin, A. A. (2016). Durability of reinforced concrete structural elements. [Durability of reinforced concrete structural elements]. *Budivnitsvo, konstruksiya, remont budivel ta sporud miskogo gospodarstva*. [Construction, construction, repair of buildings and structures of municipal economy]. Komunalne gospodarstvo mist. Vipusk 128. 5–9. [in Russian].
18. Nikola Tošić, Stanislav Aidarov and Albert de la Fuente (2020). Systematic Review on the Creep of Fiber-Reinforced Concrete. *Materials*. Basel. 13(22):5098. doi: 10.3390/ma13225098.
19. Yelizarov, S. V., Benin, A. V. (2004). Uchet polzuchesti betona i korrozii armatury pri raschete zhelezobetonnykh konstruksiy na seymstoykost. [Taking into account the creep of concrete and corrosion of reinforcement when calculating reinforced concrete structures for earthquake resistance]. *Izvestiya peterburgskogo universiteta putey soobshcheniya*. №2. 180–185. [in Russian].
20. Palivoda, O. A. (2019). Vrakhuvannya deformatsiy povzuchosti pri rozrakhunku zalizobetonnikh elementiv. [Taking into account creep deformations when calculating reinforced concrete elements]. *Naukovi visti Dalivskogo universitetu*. №16. [in Ukrainian].
21. Prokopovich, I. Ye. (1963). *Vliyanie dlitelnykh protsessov na napryazhennoe i deformirovannoe sostoyanie sooruzheniy*. [Influence of long processes on the stressed and deformed state of structures]. M.: Stroyizdat. [in Russian].

Література

1. Улицкий И. И., Чжан Я. О., Гольшев А. Б. Теория и расчёт железобетонных стержневых конструкций с учётом длительных процессов. Киев: Будівельник, 1967. 348с.
2. Бондаренко В. М., Колчунов В. И. Концепция и направления развития теории конструктивной безопасности зданий и сооружений при силовых и средовых воздействиях Промышленное и гражданское строительство, 2013. № 2. С. 28–31.
3. Селяев В. П., Соломатов В. И., Ошкина Л. М. Химическое сопротивление наполненных цементных композитов Саранск: Изд-во Мордов. ун-та, 2001. 152 с.
4. Пухонто Л. М. Долговечность железобетонных конструкций инженерных сооружений: (силосов, бункеров, резервуаров, водонапорных башен, подпорных стен). Монография. М.: Изд-во АСВ, 2004. 424 с.
5. Васильев А. И., Подвальный А. М. Прогноз коррозии арматуры железобетонных конструкций автодорожных мостов в условиях хлоридной агрессии и карбонизации. Бетон и железобетон, 2002. № 6. С. 27–32
6. Дронов А. В. Прочность и деформативность железобетонных изгибаемых элементов с коррозионными повреждениями: дис. ... канд. техн. наук: 05.23.01. Белгород, 2017. 163 с.
7. Мигунов В.Н. Длительные экспериментальные исследования моделей железобетонных конструкций с трещинами в агрессивной хлоридсодержащей среде: моногр. Пенза: ПГУАС, 2016. 404 с.

8. Овчинников И. И., Мигунов В. Н., Овчинников И. Г. Моделирование кинетики деформирования армированных конструкций в специальных эксплуатационных средах: моногр. Пенза: ПГУАС, 2014. 280 с.
9. Попеско А.И. Работоспособность железобетонных конструкций, подверженных коррозии. СПб.: СПб гос. архит.-строит. ун-т, 1996. 182 с.
10. Розенталь Н. К., Степанова В. Ф., Чехний Г. В. Хлориды в бетоне и их влияние на развитие коррозии стальной арматуры. Промышленное и гражданское строительство, 2017. № 1. С. 92–96.
11. Селяев В. П., Селяев П. В., Алимов М. Ф., Сорокин Е. В. Оценка остаточного ресурса железобетонных изгибаемых элементов, подверженных действию хлоридной коррозии. Строительство и реконструкция, 2017. № 6 (74). С. 49–58.
12. Смоляго Г. А., Дронов А. В., Фролов Н. В. Моделирование величины коррозионных повреждений арматуры железобетонных конструкций в условиях хлоридной агрессивной среды. Известия Юго-Западного государственного университета, 2017. № 1 (70). С. 43–49.
13. Сорокин Е.В. Расчет и прогнозирование долговечности железобетонных конструкций: дис. ... канд. техн. наук: 05.23.01 Саранск, 2014. 206 с.
14. Федосов С. В., Румянцева В. Е., Коновалова В. С. Исследование процессов коррозионной деструкции железобетонных изделий в агрессивных средах с хлорид-ионами. Вестник гражданских инженеров, 2016. № 5 (58). С. 61–67.
15. G. L. England. Creep and temperature effects in concrete structures: reality and prediction. Applied Mathematical Modelling. Volume 4. Issue 4. 1980. Pages 261–267.
16. Бреславский Д. В., Чупрынин А. А., Середа Н. В. Ползучесть железобетонных элементов конструкций. Вестник Нац. техн. ун-та "ХПИ" : сб. науч. тр. Темат. вып. : Динамика и прочность машин. Харьков : НТУ "ХПИ", 2015. № 55 (1164). С. 22–25.
17. Чупрынин А. А. Долговечность железобетонных элементов конструкций. Будівництво, конструкція, ремонт будівель та споруд міського господарства. Комунальне господарство міст, 2016. 128. С. 5–9.
18. Nikola Tošić, Stanislav Aidarov and Albert de la Fuente. Systematic Review on the Creep of Fiber-Reinforced Concrete. Materials. Basel. 2020. 13(22):5098. doi: 10.3390/ma13225098.
19. Елизаров С. В., Бенин А. В. Учет ползучести бетона и коррозии арматуры при расчете железобетонных конструкций на сейсмостойкость. известия петербургского университета путей сообщения, 2004. №2. С. 180–185.
20. Паливода О. А. Врахування деформацій повзучості при розрахунку залізобетонних елементів. Наукові вісті Даліського університету, 2019. №16.
21. Прокопович И. Е. Влияние длительных процессов на напряжённое и деформированное состояние сооружений. М.: Стройиздат, 1963 – 240с.

Bekirova Mariam

Odessa State Academy of Civil Engineering and Architecture
Ph.D., associate professor
Didrihsona str.,4 Odessa, Ukraine, 65029
bekirova.ogasa@gmail.com
ORCID: 0000-0002-6162-9967

For references:

Bekirova M. (2021). Stress state of compressed reinforced concrete elements considering creep and influence of an aggressive environment. Mechanics and Mathematical Methods. 3 (1). 72–82

Для посилань:

Бекірова М. М. Напружено-деформований стан стиснених залізобетонних елементів з урахуванням повзучості і впливу агресивного середовища. Механіка та математичні методи, 2021. Т. 3. №. 1. С. 72–82.